

CHALWYN

DIESEL PROTECTION SYSTEMS

D-Series Engine Overspeed Shut Down Valves (Auto/Manual Types)

SELECTION, APPLICATION AND MAINTENANCE

Valve Numbers

D40B-AM D45B-AM D51B-AM D57B-AM

D64B-AM D71-AM D75-AM D92-AM

D102-AM D121-AM D136-AM

DESCRIPTION

A range of spring loaded poppet valves designed to automatically stop an engine by closing down the air intake should excessive overspeeding occur. Fitted with manual stop pull cable.

These valves are available with standard springs or stong springs (indicated by the suffix "S" after the valve type number). The spring selection is determined by the rating of the engine to which the valve is to be fitted.

The closing force on the valve is provided by the intake air flow passing through. As the air flow increases, the closing force builds up. This is resisted by the valve spring force, the pre-load of which is adjustable such that at a given air flow the resulting force overcomes the spring resistance and causes the valve to close. Once closed the valve will not reset to the open condition until the engine stops.

This type of valve may be fitted to either naturally aspirated or turbocharged engines. It should be noted however that for a given valve setting the repeatability of the actual automatic shut down speed has a greater scatter in the case of a turbocharged engine. However, unless for special reasons a precisely repeatable shut down speed is required, adequate protection from excessive overspeed and potential resulting damage is still achieved.

SELECTION - Bendix Type

Auto/Manual valve dimensions are as below:

Valve Type	A	MIN	B	MAX	C	D	E	WEIGHT (valve only) Kg
D40B-AM	148	43		48	86	87	19	0.9
D45B-AM	148	48		70	86	87	19	0.9
D51B-AM	148	54		80	94	89	19	0.9
D57B-AM	148	60		82	104	93	19	1.2
D64B-AM	148	67		96	114	94	19	1.4
D71B-AM	148	76		108	125	94	19	1.6

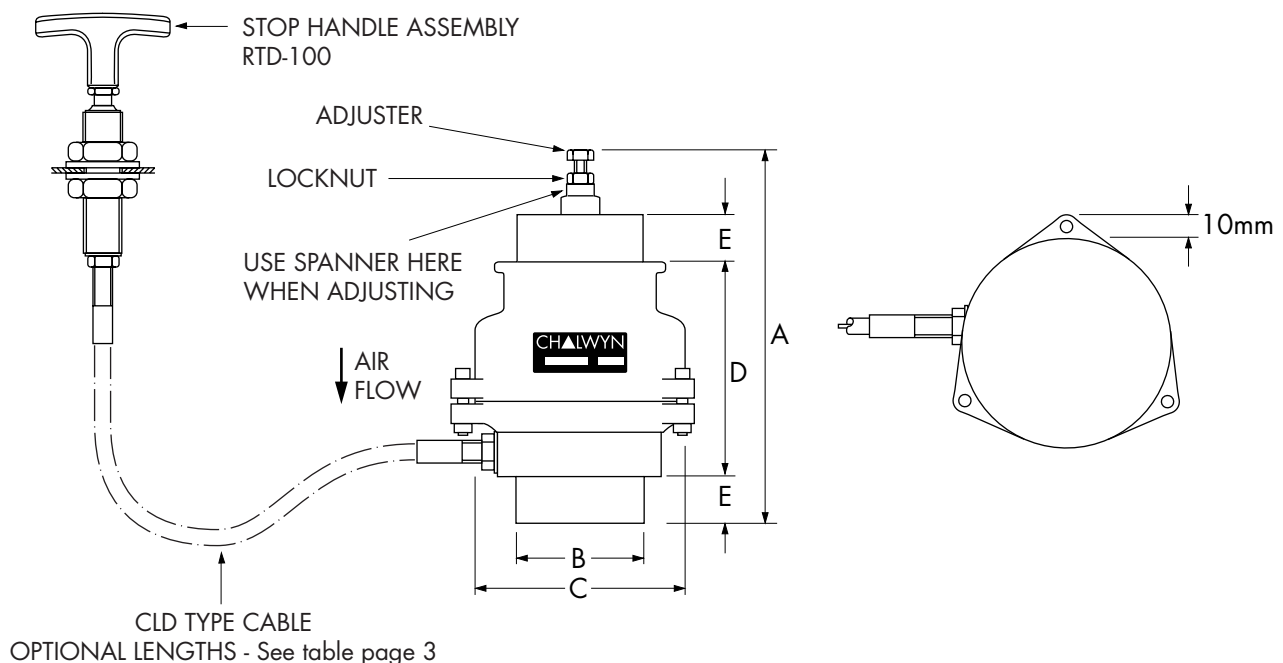

SELECTION - Spindle Type

Auto/Manual valve dimensions are as below:

Valve Type	A	B		C	D	E	WEIGHT (valve only) Kg
		MIN	MAX				
D75-AM	203	70	102	137	111	28	1.8
D92-AM	252	76	114	160	121	28	2.1
D102-AM	252	89	114	176	124	28	4.5
D121-AM	308	101	140	206	139	28	4.6
D136-AM*	308	126	154	232	151	28	5.5

* Stop lever RLD-100 is used with D136-AM valves and not handle assembly RTD-100.

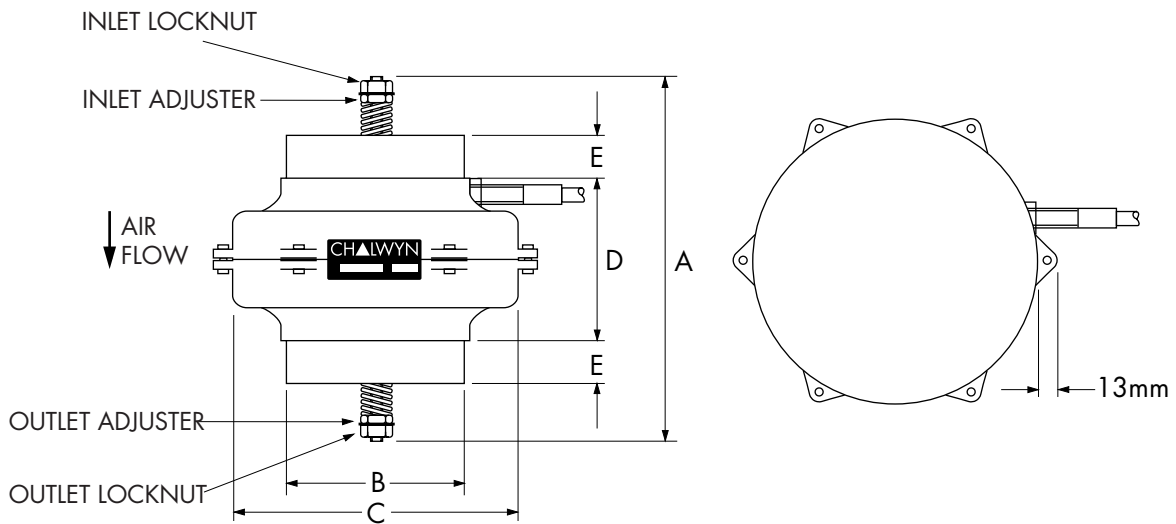

Notes:

- Dimension 'B' is selected within the range given to match the engine air intake pipework.
- For smaller valves with manual shut down option see Chalwyn Mini Range data sheets.
- For larger valves with manual shut down option see D200 data sheet.
- In order to select the correct valve build the following information is required:
 - a) Engine type.
 - b) Engine rating (power and speed).
 - c) Inside diameter of the engine intake hose into which the Chalwyn valve is to be fitted.

Also select the cable length required from the range given below.

Note: Other lengths may be available on special request.

CABLE PART N°	LENGTH (metres)
CLD-100	1.0
CLD-150	1.5
CLD-200	2.0
CLD-300	3.0

SELECTION - Optional (non-preferred) Loop Cable

These valves are identified by a "M" prefix (e.g. MD64B, MD102S etc)

BENDIX TYPE VALVE WITH LOOP CABLE

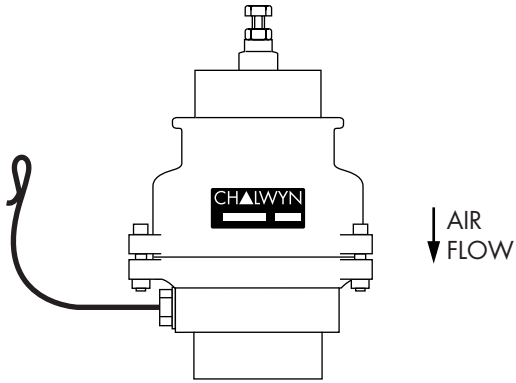

SPINDLE TYPE VALVE WITH LOOP CABLE

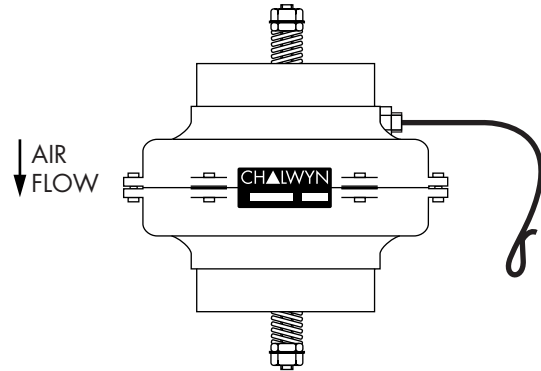

This option remains available for established applications only.

Exposed length of cable varies from about 150mm (6") to 300mm (12") subject to valve model.

Cable is pulled to give manual shut down.

There are no "MD" versions of the D30, D34, D35, D39, D71, D136 and D200 valves.

FITTING

1. Chalwyn auto/manual shut down valves are supplied complete with the manual stop cable and 'T' handle fitted and adjusted. Do not separate the cable from handle or valve (see paragraph 7).
2. The shut down valve is designed for fitting as close to the engine air intake manifold as possible. Where an engine air intake flametrap is also fitted, the Chalwyn valve should be positioned immediately on the air cleaner side of the flametrap. These same requirements are applicable to both naturally aspirated and turbocharged engines albeit in the latter case there is sometimes insufficient space to fit the Chalwyn valve between the turbocharger and intake manifold. Under this circumstance, the shut down valve may be fitted on the upstream (air cleaner) side of the turbocharger but should otherwise still be in compliance with the preceding requirements.

Note: Where the valve is fitted immediately upstream of the turbocharger, ensure that the valve spindle does not project into the turbocharger when the valve closes.

3. Where more than one Chalwyn valve is fitted to an engine as in the case of an engine with multiple intake pipes, a balance pipe arrangement must be installed to connect the various intake pipes together downstream (engine side) of the shut down valves. Typically balance pipe diameters should be about 30% of the diameter of the intake pipes.
4. When fitting, the direction of the air flow arrow on the Chalwyn valve must be observed. The valve may be installed with the direction of air flow anywhere between vertically down and horizontal. The cuffs at the inlet and outlet of the valve should be of a re-inforced type, provide adequate support for the valve and prevent excessive vibration. If necessary, additional support brackets mounted from the engine should be considered.
5. Particular care must be taken to ensure the integrity of the intake pipework between the Chalwyn valve and intake manifold. Ideally metal pipework should be used and any gaps kept as short as possible, taking into account any relative movement, and closed by re-inforced hose. The possibility of a hose collapse on closure of the shut down valve should be avoided.

6. Any engine crankcase breather connections into the intake system between the Chalwyn valve and engine, or any internal crankcase breather arrangement venting directly into the engine intake ports, must be sealed and replaced by an external breather system venting either to atmosphere or to the intake system upstream of the shut down valve. External breather system kits for various engine types are available from Chalwyn.
7. Fit the 'T' handle assembly RTD-100 through a suitable $\text{\O}20\text{mm}$ $3/4"$ dia hole in a bulkhead or mounting bracket as follows. Release the handle locknut. Remove the handle, handle locknut and upper locknut and washer. Thread handle body through the bulkhead/bracket. Refit upper locknut and washer. Adjust lower and upper locknuts to position handle and tighten. Refit handle locknut and handle. Tighten locknut.

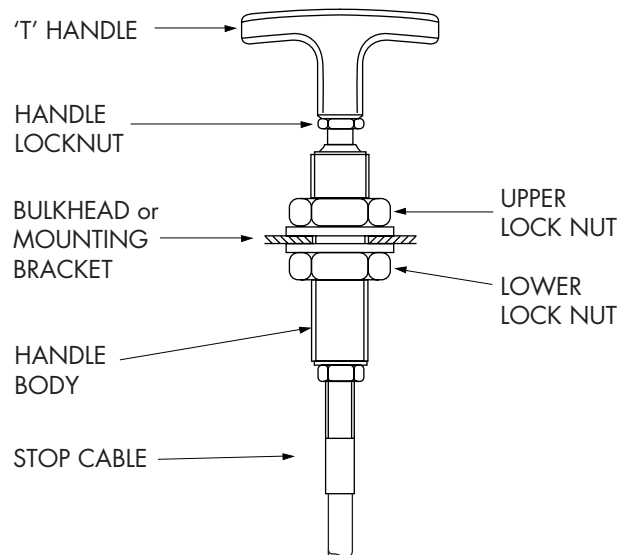

Note: On larger spindle valves it requires significant force to move the valve to the fully closed position using the RTD - 100 handle whilst the engine is not running. This is a design feature and adjustment is not necessary. When the engine is running, manual shut down will be achieved satisfactorily using considerably less force to operate handle RTD - 100.

ADJUSTMENT

Once the Chalwyn valve is installed, adjustment of the overspeed trip setting is carried out using the adjuster and locknut (refer to diagrams). Basically rotating the adjuster clockwise will increase the engine speed at which automatic shut down occurs.

As supplied, the valve will be adjusted such that shut down will generally occur well below the engine high idle speed. To increase the speed at which automatic shut down occurs, proceed as follows:

1. Check that the manual shut down cable is in the run condition i.e. the 'T' handle is pushed inwards.
2. Start engine. Slowly accelerate. Note speed at which shut down occurs.
3. Remove hose at **air inlet** to Chalwyn valve to expose the adjuster and locknut (see diagram).
4. Release locknut. Turn adjuster clockwise one turn. Tighten locknut.
5. Refit inlet hose to valve.
6. Start engine. Slowly accelerate. Note speed at which shut down occurs.
7. Repeat steps '3' to '6' until the first setting at which the engine does not shut down at high idle speed (i.e. full throttle, no load). Then either:
 - a) Use the results of shut down speed versus adjuster setting as a calibration check to make a final adjustment to give the required setting (typically 10% to 15% over high idle).
 - or**
 - b) If a very precise setting is not required, turn the adjuster a further one turn clockwise to take the shut down above high idle speed by a suitable margin. When using this setting procedure it may be found that the engine occasionally shuts down during the normal operation. If so, turn the adjuster clockwise by a further one half turn.
8. Ensure the adjuster locknut is fully tightened. (Use a thread lock adhesive on the locknut threads).

Notes:

Turbocharged Engines

When setting a valve fitted to a turbocharged engine using the preceding method, it may be found that at high engine power outputs, the engine will shut down at a lower speed than required. If this occurs, further small adjustments in steps of one half turn clockwise should be made until the problem is eliminated.

Insufficient Adjustment

Should there be insufficient adjustment available to set the required overspeed trip point then proceed as follows:

- a) *Bendix Type Valve. Contact your Chalwyn agent for supply of a stronger valve spring.*
- b) *Spindle Type Valve. Release the outlet locknut. Rotate the outlet adjuster by four turns anticlockwise. Tighten outlet locknut using a thread lock adhesive. Further adjustment to the inlet adjuster as per above instructions is then continued.*

Jammed Bendix Type Valve

If in the course of adjusting a Bendix Type valve it jams on its seat, release by turning **CLOCKWISE** viewed from adjuster end.

MAINTENANCE

The recommended routine maintenance period is three months. This period is dependent on the operating conditions of the engine and, by experience, may need to be varied.

Routine Maintenance

1. Disconnect intake pipework and release the valve from any support brackets etc. to allow it to be removed.
2. Inspect the valve internally for cleanliness. If necessary, clean in paraffin or white spirit taking normal precautions. Dry the valve thoroughly.
3. Check there is no excessive wear and that the valve moves smoothly over its complete operating stroke. **DO NOT LUBRICATE.**
4. Refit valve. Check valve setting based on the "Adjustment" instructions given herein.
5. With the engine running at medium speed pull the manual stop handle. The engine should come to a complete stop within a few seconds.

Valve Reconditioning

When excessive wear is noted or the valve damaged it should be returned to Chalwyn Limited for appraisal and reconditioning.

(All such work is dealt with on an urgent basis.)

CHALWYN LIMITED

Chalwyn Industrial Estate, Parkstone, Poole, Dorset BH12 4PF ENGLAND

Tel: +44(0)1202 715200 Fax: +44(0)1202 715600

www.chalwyn.co.uk

CE207 - 15



CHALWYN LIMITED RESERVE THE RIGHT TO UPDATE THIS PRODUCT SPECIFICATION WITHOUT PRIOR NOTICE.